

RAISE BORING MACHINE

www.terratec.co



 **TERRATEC**

RAISE BORING TECHNOLOGY

Raise boring, as a technique or system of driving raises (vertical or near vertical holes) continues to gain in popularity due to its many important advantages over conventional methods.

With its experienced team of engineers, TERRATEC has developed its own series of Raise Boring Machines, providing innovative solutions to the traditional Raise Boring Machine for the underground industry.

ADVANTAGES OF BORED RAISES

Raise boring offers several advantages over the conventional drill and blast method. The most important are safety, speed, physical characteristics of the completed hole, labor reduction and cost reduction.

The safety factor in raise drilling cannot be over emphasized. No men are exposed to the danger of rock fall from freshly blasted ground or to the continual use of explosives, with their fumes and inherent danger of misfires. Raises can be safely drilled in ground that would be extremely hazardous, if not impossible, to drive by conventional methods.

A hole drilled by Raise Boring Machine can generally be completed in a fraction of the time required for conventional methods.

TERRATEC's RBM programme incorporates standard Raise-Boring Machines (TR Series), which are used in mining and civil construction to excavate large diameter single pass (1 to 6 meters) holes in hard rock. The Combination Down-Reaming/Rise-Boring (TDR Series) and Universal Borers (UB) Machines round off the product range required to drill a hole. The purpose of the hole can be for ventilation, ore passes, access ways, man movements or vertical conveyors.

The bored raise, with its firm undisturbed walls, is more adaptable to use as ventilation and rock passes. As conventional methods require a relatively large opening, it has become customary to drive raises larger than actually required for ore and rock passes, a fact that long experience has borne out. The advantage of smooth walls in ventilation raises is well known.

Raise boring will not only reduce labor requirements by achieving a higher advance per day but, along with another technological advances, will have the tendency to attract a higher level of skilled labor to the mining industry.

Last, and probably most important from the long-range viewpoint, is cost reduction. Although, it is true that the



direct cost of conventional raises, especially short ones, may currently be less in many cases, labor and material costs are continually escalating and therefore their costs increasing. Skilled conventional miners, always in short supply, are not required to operate a Raise Boring machine. Improved raise drills, drilling techniques, pilot bit and cutters are lowering the cost of machine excavated (RBM) raises. Less total manpower, less rock to handle, less construction time and increased safety all add up to less costs and earlier projects.

RAISE BORING METHODS

Three basic systems of Raise boring

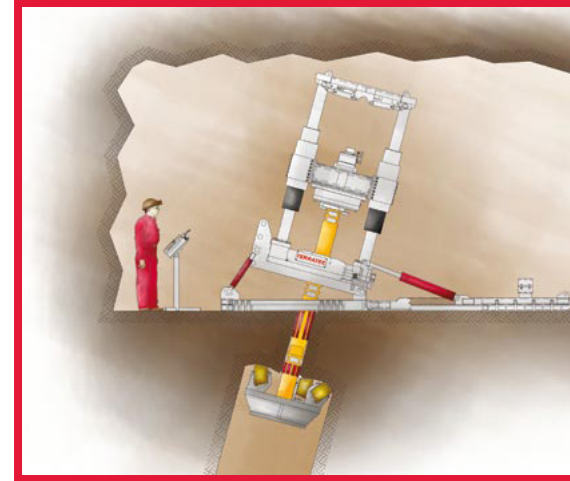

RAISE-BORING

In this system, the pilot hole is drilled down to a lower level in the mine or civil project. Once the pilot hole connects to the lower access level in the rock, the drill bit is removed and a reamer or raise head is attached and the reamer is rotated and pulled upwards. The broken rock falls to the lower level by gravity. This system operates with the drill string in tension and this provides the most stable platform.

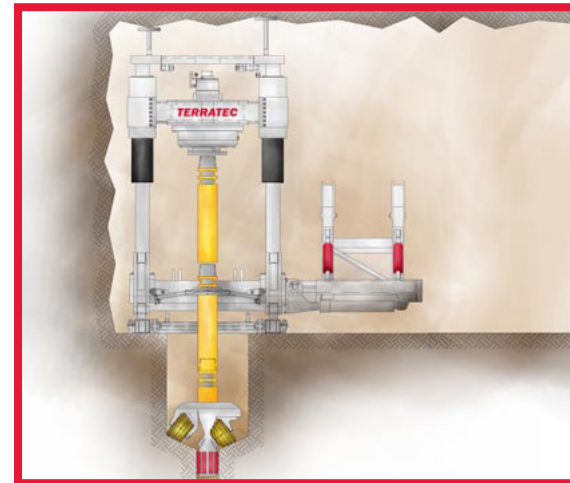

DOWN-REAMING

In this system, the pilot hole is drilled downwards until it connects to a lower access level. The drill string (all drill rods, stabilizers and cutting bits) is retrieved and then a reamer is pushed downwards. The cuttings flow down the previously drilled pilot hole. This method uses drill string in compression and usually stabilizers must be installed to eliminate the potential of the drill string buckling.

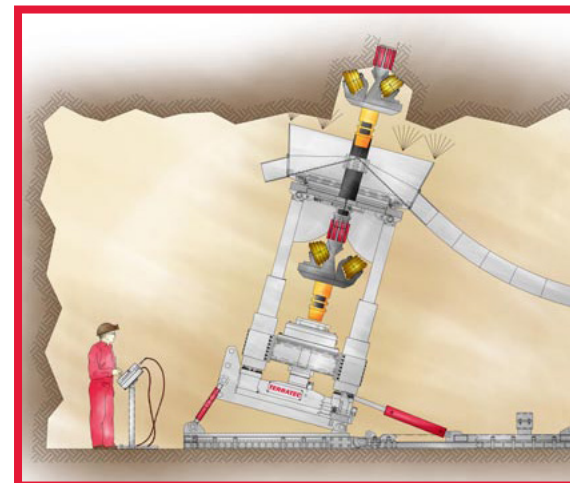

BOX-HOLING

The most difficult raise method, known as Box-Hole excavation, is to drill a pilot hole to any level up from the raise borer. Once the desired length is achieved the drill string is retrieved, and a reamer attached and pushed upwards. The broken rock falls down the enlarged hole onto a special collection chute attached to the top of the raise borer. This technique has been largely used to replace ladder rises, which completes the boxhole using conventional methods. Ladder rise excavation is very dangerous and is being legislated out of the industry in favour of mechanical means. TERRATEC's engineers have designed the boxhole excavation system to be a safe and reliable process of drilling.

TERRATEC RAISE BORING MACHINES

TR SERIES

The original and most traditional series of Raise Boring Machines is the TR (Terratec Raise) series. These machines are designed to execute raises by Raise-Boring method only.

These drills can be manufactured for the excavation of up-reamed large shafts in diameter up to 6,000mm in a single pass.

TERRATEC RAISE BORERS' UNIQUE FEATURES:

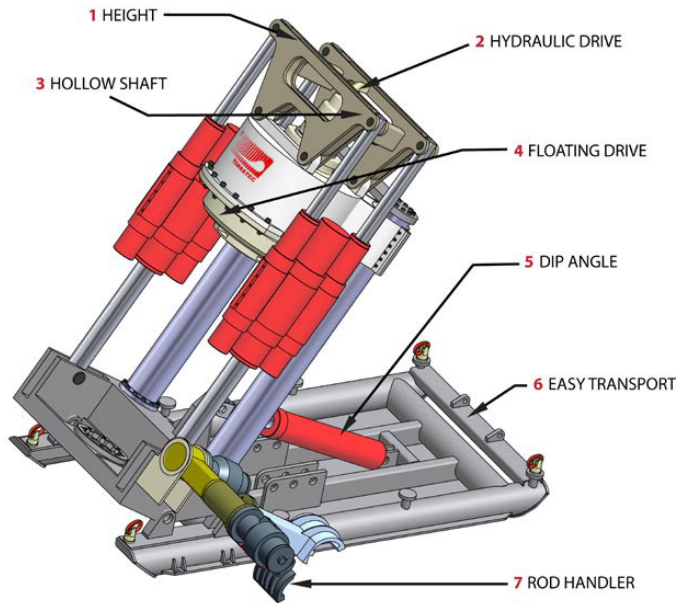

1. HEIGHT

TERRATEC's Raise Drills have the lowest standard profile in the industry.

2. HYDRAULIC DRIVE

Stepped hydraulic system for easy use and maintenance. Hydraulic control protects the Drilling Rods from Over-torque thus ensuring a longer life for them.

3. HOLLOW SHAFT

Hollow Shaft design on Gearbox and Drive Motor to allow flushing while boring the Pilot Hole.

4. FLOATING DRIVE

Manufacture is from forged steel for extra strength and with a unique sealing system which stops bailing water corroding the drive spline.

5. DIP ANGLE

Easy dip angle selection achievable with a single erection cylinder.

6. EASY TRANSPORT

Main sled structure manufactured from circular tube which assists with slew operations.

7. ROD HANDLER

It can lift all the Drill Strings, the Reamer and the Stabilizers enabling "One-Man" operation.

Power Unit

All TERRATEC Raise Borers install a unique Hydraulic Power Unit consists of a single sled containing all major hydraulic and electrical components including the motor pump assemblies, hydraulic reservoir, heat exchanger, filter, manifold block and stainless steel electrical cabinet. The Hydraulic System is fully controlled by a PLC, and the hydraulic components are universally available.

Reliability, low and ease of maintenance and operator acceptance (user friendly) are of paramount consideration in the design procedure.



TDR SERIES

The dual purpose Raise/Down drilling machine is able to pass all drilling components through the worktable, including the Reamers. Consequently due to the machine being robustly designed for easy use and reliability, the system only requires one operator and it can be left unattended when required.

The derrick of the machine is designed in modular units which makes disassembly of major components (for inspection, transport or repair) very easy to achieve. The prime feature of this machine is the hinged "horizontal double worktable doors" which swing up to allow a Reamer and Stabilizer to pass through



the worktable doors. The swinging motion of the doors is controlled by the operator, via an electrical pushbutton on the control console.

These machines are designed to have sufficient torque and thrust capability to operate as a conventional Raise Boring Machine, but are sought after for their ability to down ream. This entails pilot drilling for guidance and spoil removal, then reaming downwards. The machines have sufficient equipment for rod handling capacity to lift the fully dressed reamer into the machine without any auxiliary external equipment; hence this machine can be controlled by one operator.



PROJECT REPORT: TR3000 FOR MEXICO

RBM Type:	TR3000
Series Number:	R15
Location:	Mexico
Year:	2012
Customer:	CAUSA
Norminal diameter:	3,000 mm
Norminal Hole Depth:	500 m
Installed Power:	352 kW
Torque:	
Pilot Drilling	78,000 Nm
Reaming Norminal	237,000 Nm
Reaming Maximum	266,000
R.P.M.:	
Pilot Drilling	0 - 57
Reaming	0 - 14
Thrust:	
Down	1,600 kN
Up	4,500 kN
Derrick Dip Angle:	0° ~ 30°
Derrick Extended Height:	4,490 mm
Drill String Length:	2,300 mm



Low Profile

For those applications with very restricted space, TERRATEC implements the very Low Profile "L" Special Series. A sample of it is the TDR-L-600 which can ream 720mm upwards and 1,500mm downwards using 48" Rods in only 3.5m overall extended derrick height.



UB SERIES

TERRATEC's ultimate drill is its Universal Borer. With this one system, Raise-Boring, Down-Reaming and Box-Holing can be accomplished using the same derrick assembly. The design ensures maximum safety for the operating personnel on site giving a safe working environment.

Main Features of this System:

- Fast Interchangeability
- One-Man Operation
- Powered Pipe Handling & Muck Chute
- Diameter Range of 600mm to 1,500mm
- Integrated Thrust Torque Cylinders
- Modular Compact Design
- Cost Effective
- Exclusive Safety Features

By changing the floating drive box the machine can operate with 10 inch or 11¼ inch drill rods. However, TERRATEC machines are designed to fully utilize the capability of the various drill string.



TOTAL SOLUTION

TERRATEC's scope of work is not limited to the supply of the Raise Boring Machine itself. We can provide the whole package of accessories needed to perform the work, such:

- Drill Pipes
- Stabilizers
- Reamers
- Tungsten-Carbide Button Cutters
- Crawlers and Transport Systems



Crawlers



Reamers & Cutters

TERRATEC's experienced Engineering and Field Service Teams can assist the Buyer from the Planning Stages at the mine site, design to suit the required specifications, and for the assembly and operation of the RBM once the actual works begin at site.

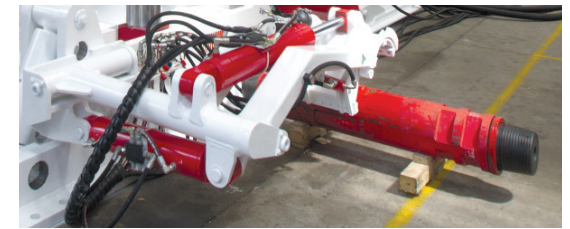

Drill Pipes

TERRATEC'S STANDARD RAISE BORING MACHINES

FEATURE			UB SERIES	TDR SERIES				TR SERIES			
			UB-1000	TDR-600	TDR-1000	TDR-2000	TR-2000	TR-3000	TR-4000	TR-6000	
MAX. HOLE DIAMETER	Raise-Boring	[mm]	1,500	1,500	1,500	2,400	2,000	3,000	4,000	6,000	
	Down-Reaming		1,060	720	1,150	1,800	~	~	~	~	
	Box-Holing		1,060	~	~	~	~	~	~	~	
MAX. HOLE DEPTH (at Max. Hole Diameter)	Raise-Boring	[m]	200	200	200	250	250	400	500	600	
	Down-Reaming		200	200	200	250	~	~	~	~	
	Box-Holing		200	~	~	~	~	~	~	~	
PILOT HOLE	Bit Diameter	[mm]	279	279	279	279	279	311	349	406	
	Rod Diameter		254	254	254	254	254	286	327	378	
	Rod Length		1,066	1,524	1,524	1,524	1,524	1,524	1,524	1,524	
INSTALLED POWER		[kW]	121	97.5	121	242	242	352	450	704	
TORQUE	Pilot Drilling	[Nm]	11,700	8,600	8,600	31,000	78,000	78,000	78,000	135,000	
	Reaming Nominal		61,000	43,400	43,400	175,000	175,000	237,000	373,000	675,000	
	Reaming Maximum		73,000	52,500	52,500	203,000	203,000	275,000	475,000	810,000	
ROTATION SPEED	Pilot Drilling	[rpm]	0 ~ 80	0 ~ 120	0 ~ 120	0 ~ 60	0 ~ 60	0 ~ 42	0 ~ 42	0 ~ 42	
	Reaming		0 ~ 16	0 ~ 23	0 ~ 23	0 ~ 14	0 ~ 14	0 ~ 10	0 ~ 10	0 ~ 8	
THRUST	Down Ream	[kN]	1,100	550	750	1,647	530	1,600	1,600	1,600	
	Up Ream		1,100	985	1,400	3,100	3,100	4,500	6,700	13,300	
DERRICK DIP ANGLE	From the Vertical	[deg]	0° ~ 30°	0° ~ 30°	0° ~ 30°	0° ~ 30°	0° ~ 30°	0° ~ 30°	0° ~ 30°	0°	
MAX DIMENSIONS	Height*	[mm]	4,392	4,495	4,195	4,650	4,350	4,490	4,600	5,800	
				(3505)	(2980)	(3950)	(3820)	(3960)	(4070)	(5500)	
(Derrick Operating)	Width	[mm]	3,050	2,150	2,550	3,180	2,250	2,300	2,700	2,850	
	Length		2,450	5,040	5,970	6,670	1,950	2,300	2,600	2,800	
WEIGHT (Derrick only)		[kg]	14,000	9,300	12,100	19,350	13,500	17,200	21,000	29,000	

* The dimensions shown between brackets correspond to the ones of the Low Profile "L" Version
Apart from these standard models, TERRATEC can tailor make the Raise Boring Machine to meet any special requirements

REMOTE DIAGNOSIS



Our optional Remote Diagnosis Program also allows to monitor the actual works of the Machine from TERRATEC's Engineering Center and to detect any malfunction or abnormal symptom on the machine, preventing any damage and ensuring a long life for the RBM.

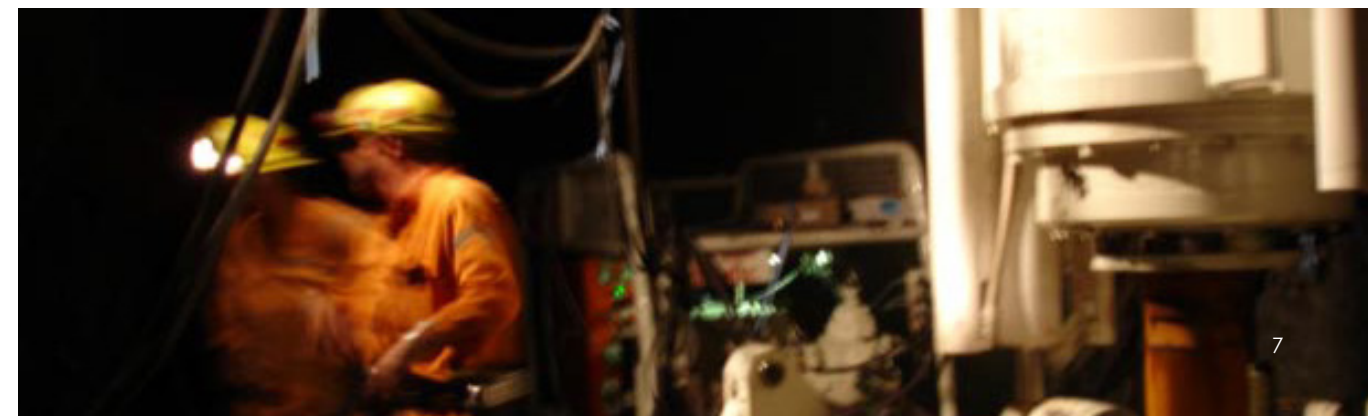
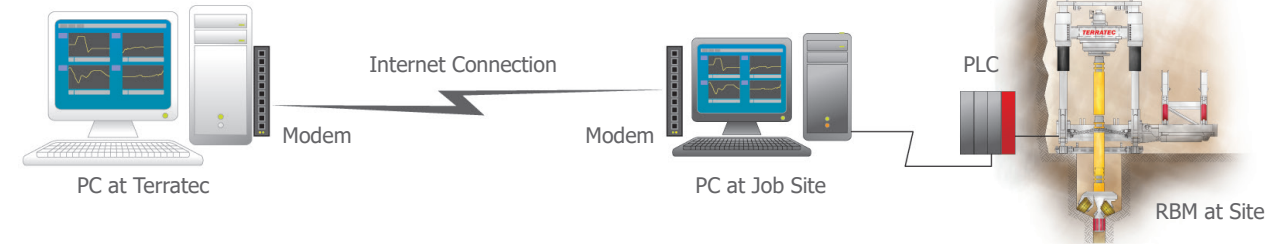



AUSTRALIA

171 Davey Street,
Hobart, Tasmania,
7000 AUSTRALIA
Tel. +61 362233282
Fax. +61 362233268
E-mail: info@terratec.com.au

CHINA & SOUTH EAST ASIA

11/F Wharf T&T Centre,
7 Canton Road,
Kowloon, HONG KONG
Tel. +852 3169 3660
Fax. +852 3169 3661
E-mail: info@terratec.com.hk

INDIA

4F, Ansal Chamber-2
Bhikaji Cama Place,
New Delhi, 110066 INDIA
Tel. +91 11 46695021
Fax. +91 11 26169111
E-mail: info@terratec-india.com

www.terratec.co